



STEEL WHEEL RIM MANUFACTURING LINE



Focus on the high-end equipment manufacturing industry R & D and manufacturing

SHANDONG XIAOYA PRECISE MACHINERY CO., LTD.
No.51 GONGYE NAN ROAD, JINAN 250101 CHINA



Little Duck



ABOUT US



Shandong Xiaoya (LittleDuck) Precise Machinery Co., Ltd. is a wholly-owned subsidiary of Shandong Xiaoya (LittleDuck) Group, and is a high and new technology enterprise that specializes in the development and manufacture of automobile mold, auto steel metal parts, wheel mold, intelligent wheel manufacturing line, and the special sophisticated CNC equipment, with

PRODUCTION FLOORS

21,000 m²

EMPLOYEES

450

ENGINEERS

50 +

NATIONAL PATENTS

30 +

QUALITY CERTIFICATE

ISO 9001, ISO/TS 16949

VIP CUSTOMERS

SINOTRUCK, FAW , DFAC ETC.

BRAND (China Market) |

LOGO

Xiaoya



BRAND (International Market) |

LOGO

LittleDuck



We adhere to the company philosophy of "create value for customers", always persist firmly in focus on the R&D and manufacturing of high-end equipments and tools, and devote ourselves to create the aircraft carrier of high-end equipments, tools and auto steel metal parts industry. The endeavoring and rising LittleDuck Precise boosts your career more successful!



STEEL WHEEL RIM MANUFACTURING LINE



APPLICATION

The steel wheel rim manufacturing line is used for processing steel wheel rims which is made of low carbon steel plate for car, bus, truck, tractor, trailers, road and construction machinery, agricultural equipment.

FEATURES BENEFITS

Xiaoya Precise Machinery is not only the market leader in steel rim manufacturing equipment, but also in optimizing wheel manufacturing processes, which leads to:

Easy operation, by manual controller and computer.

Improved manufacturing efficiency, by integrated design and excellent process layout.

Improved products quality, by meticulous design, precise technology and fine processing.

Improved tooling service-life, by highly uniform between tooling and special-purpose equipment.

Reduced the labor intensity, by automatic mechanical sub-systems.

Flash butt welding machine adopted inverter power supply design for energy saving and reducing weld scrap rates.

Adopting high-speed die-changing structure to raise the efficiency.

Saved labor costs, by intensive production and intelligent equipments; only need 3 operators to operate the manufacturing line with an annual capacity of 700,000 wheel rims.





STEEL WHEEL RIM MANUFACTURING LINE



SPECIFICATION

The steel wheel rim manufacturing line can be designed three (3) kinds of spec with different processing range, as following:

☞ Small size rim line:

Rim diameter 13 inch ~ 18 inch, rim width 3 inch ~ 10 inch, thickness ≤ 4 mm

☞ Larger size rim line:

Rim diameter 17.5 inch ~ 26 inch, rim width 5.5 inch ~ 16 inch, thickness ≤ 8 mm

☞ Extra large size rim line:

Rim diameter 20 inch ~ 54 inch, rim width 7 inch ~ 28 inch, thickness ≤ 8 mm



MAIN EQUIPMENTS

The steel wheel rim manufacturing line mainly includes coiler machine, AC flash butt welding machine, trimmer-planisher-end cutting unit, horizontal flaring machine, roll forming machine, expanding machine, Valve hole press machine, press-fitting machine, combined welding machine, hydraulic system, control system

OPERATING PERSONNEL

Semi-automatic production line, need around 10-12 workers at single machine operation mode.

Automatic production line, need around 3-5 workers.





PRODUCTION PROCESS CHART

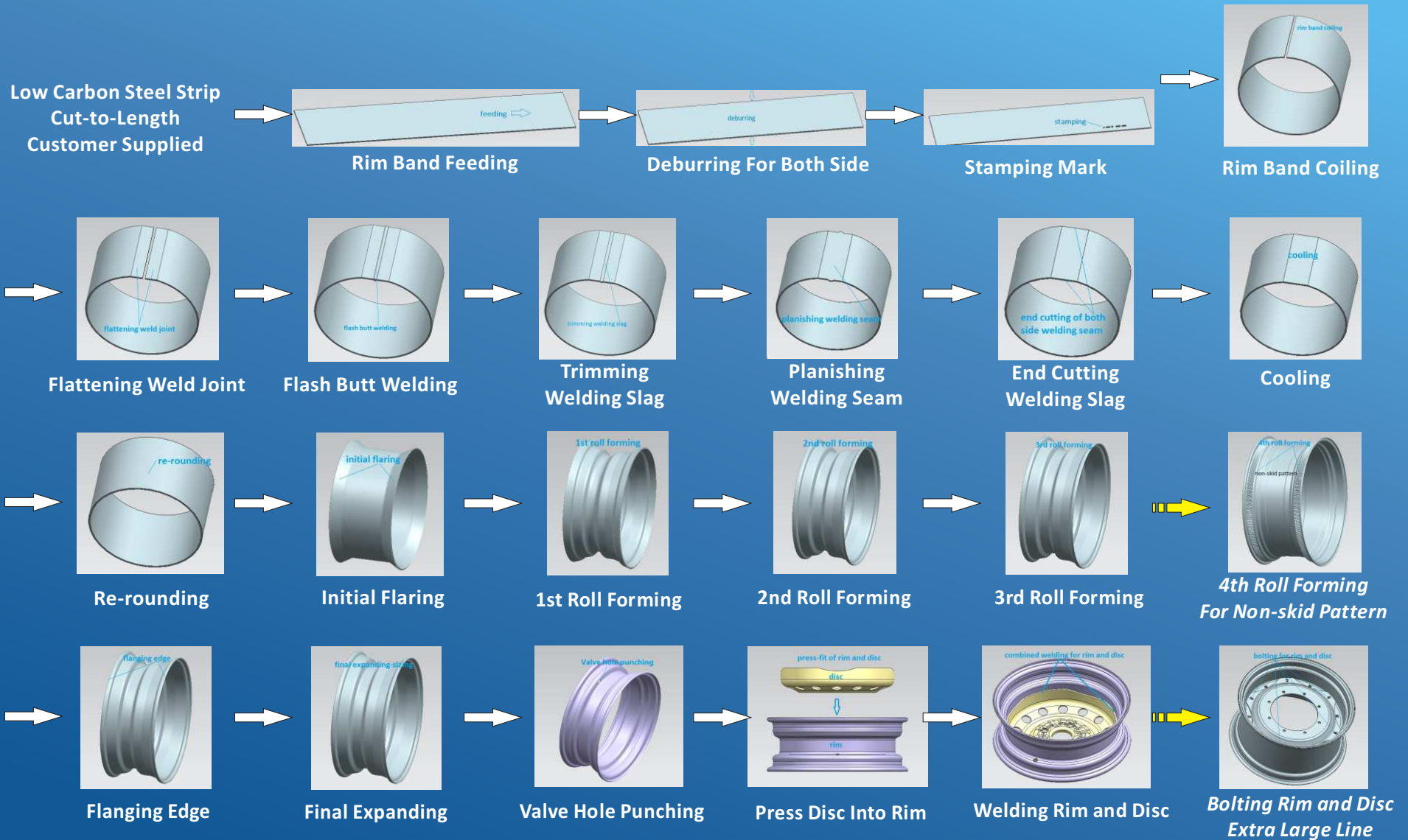



REFERENCED PRODUCTION PROCESS & EQUIPMENT



Step	Production Process	Production Equipment	small rim line dia. 13'-18'	large rim line dia. 17.5'-26'	extra large rim line dia. 20'-54'
1	rim band feeding	coiler machine	✓	✓	✓
2	deburring both side		✓	✓	✓
3	stamping mark		✓	✓	✓
4	rim band coiling		✓	✓	✓
5	flattening weld joint	flattener press	optional	✓	✓
6	AC flash butt welding	butt welding machine	✓	✓	✓
7	trimming welding slag	trimmer-planisher-end cutting unit	✓	✓	✓
8	planishing welding seam		✓	✓	✓
9	end cutting of welding seam		✓	✓	✓
10	cooling	cooling tank	✓	✓	✓
11	re-rounding	re-round press	✓	✓	✓
12	initial flaring	horizontal flaring machine	✓	✓	✓
13	1st roll forming	roll forming machine	✓	✓	✓
14	2nd roll forming		✓	✓	✓
15	3rd rollforming		✓	✓	✓
16	4th roll forming for non-skid		no-need	no-need	✓
17	final expanding-sizing	horizontal expanding	✓	✓	✓
18	flanging edge	flanging edge machine	optional	optional	optional
19	valve hole punching	valve hole press machine	✓	✓	✓
20	press disc into rim	press-fitting machine	✓	✓	no-need
21	combined welding rim and	combined welder	✓	✓	no-need
22	bolting for rim and disc	tooling	no-need	no-need	✓

According to user's requirements, we can design the production process and equipments to meet your needs.



APPLICATION - EXTRA LARGE LINE FOR RIM 20'-54'

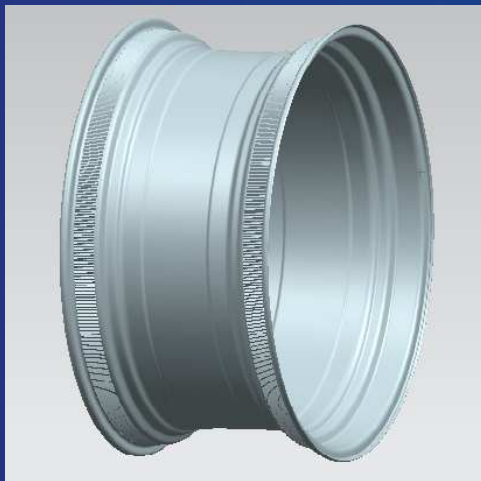
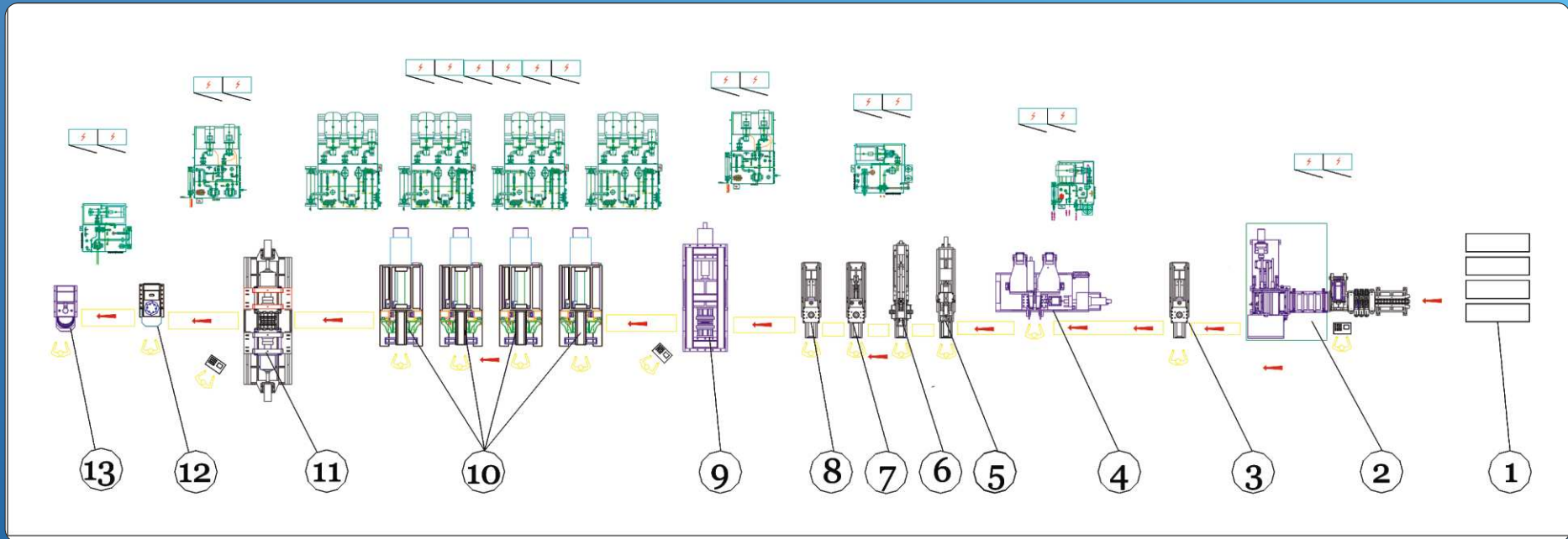

Step	Process Description	Qty.
1	Cut-to-length by customer	
2	Coiler	1
3	Flattener	1
4	AC Flash Butt Welding Machine	1
5	Weld Seam Trimmer	1
6	Weld Seam Planisher	1
7	End Cutting Machine	1
8	Re-rounding Press	1
9	Horizontal Flaring Machine	1
10	Roll Forming Machine with 4 process	4
11	Horizontal Expanding Machine	1
12	Valve Hole coining & punching Press	1
13	Valve Hole Deburring Press	1

Extra Large Size Rim Line

Application: for tractor rim, road and construction machinery's rim, agricultural equipment's rim.

Rim diameter: 20 inch ~ 54 inch

Rim width: 7 inch ~ 28 inch

Material thickness $\leq 8\text{mm}$

Operation: semi-automatic single machine



PROJECT AND ENGINEERING DESIGN



We have strong technical force, can provide project and engineering design according to customers' requirements, and have the province-level engineering technology research center, the province-level enterprise technical center, and the postdoctoral scientific research workstation. Because of over 30 national patents in our possession, we are the "patent star company in Shandong Province" and "the first independent innovation-driven company in Jinan".

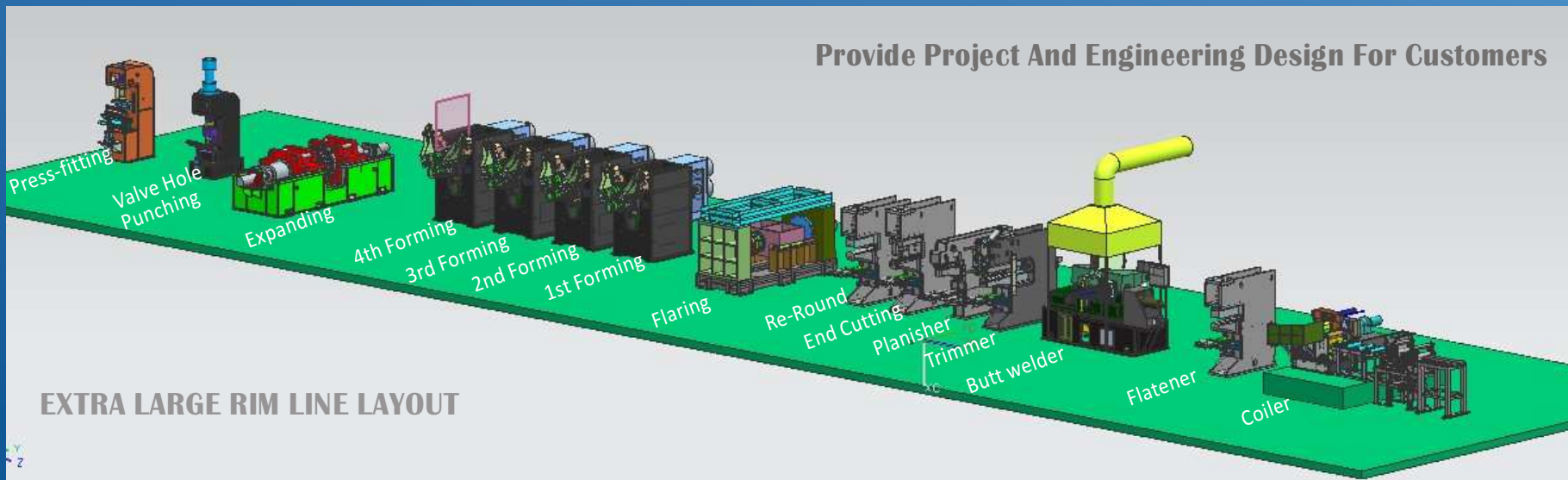



QUALITY CERTIFICATE



ISO9001:2008 Quality Management System Certificate

For design and production of stamping die and steel wheel production line

ISO/TS16949:2009 Certificate of Registration

For production of stamping parts





COILER MACHINE - production process

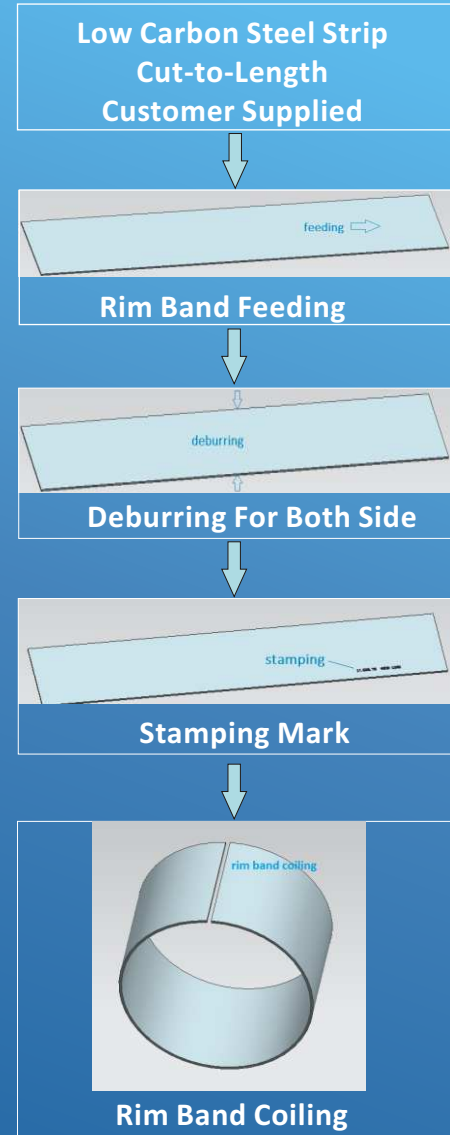



COILER MACHINE - specification



application		small rim line	large rim line	extra large rim line
rim diameter range		13inch to 18inch	17.5inch to 26inch	20inch to 54inch
rim band thickness		≤4mm	≤8mm	≤8mm
rim band width		3inch to 10inch	5.5inch to 16inch	7inch to 28inch
main machine spec	feeder	available	available	available
	deburrer	JMC-100	JMC-100	JMC-100
	stamper	DZJ-120	DZJ-120	DZJ-120
	coiler	QYJ-600	QYJ-800	QYJ-1500
input power	deburrer power	4kw	5.5KW	5.5kw
	coiler power	7.5kw	11Kw	11Kw
	input total power	11.5kw	16.5KW	16.5
coiling roller diameter		155mm	165mm	175mm
coiling roller speed		88r/min	63r/min	63r/min
power supply		AC 380V/3phase/50Hz, Can be customized		





AC FLASH BUTT WELDING MACHINE - production process

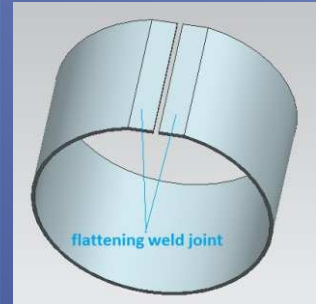
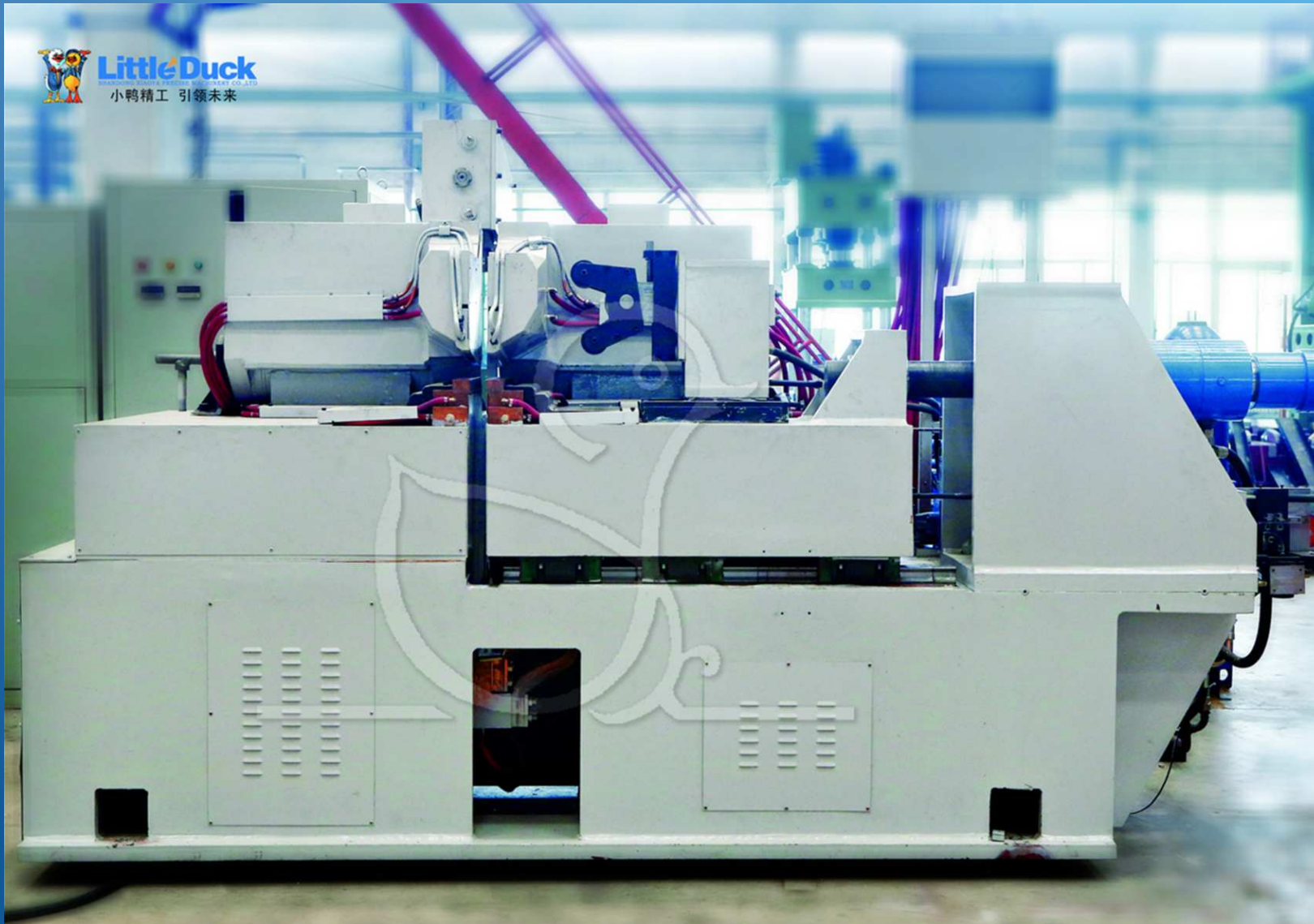

After Flattening



Flash Butt Welding

- ✔ Clamping
- ✔ Flashing
- ✔ Burn-off
- ✔ Upsetting

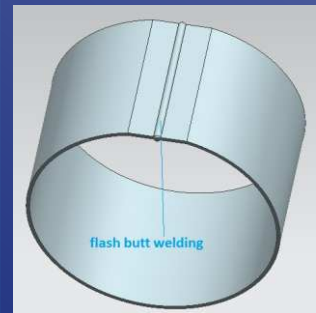



AC FLASH BUTT WELDING MACHINE - specification



1	Model number	UNB2-630	UNB2-800	UNB2-1000	UNB2-1600
2	Main circuit rated input voltage	380V/1Phase/50Hz	380V/1Phase/50Hz	380V/1Phase/50Hz	380V/1Phase/50Hz
3	Control circuit rated input voltage	380V/3Phase/50Hz	380V/3Phase/50Hz	380V/3Phase/50Hz	380V/3Phase/50Hz
4	Secondary voltage	6.55V to 11.8V	8.8V to 14.6V	8.8V to 14.6V	8.8Vto19.6V
5	voltage of solenoid valve	DC 24V	DC 24V	DC 24V	DC 24V
		YV11, YV12 @AC220V	YV11, YV12 @AC220V	YV11, YV12 @AC220V	YV11, YV12 @AC220V
6	Total power input	630KVA	825KVA	1050KVA	1610KVA
7	Rated power at transformer utilization factor 50%	600KVA	800KVA	1000KVA	1600KVA
8	Max. upsetting force	280KN	320KN	320KN	400KN
9	Max. clamping force	650KN	650KN	650KN	650KN
10	Max. welding cross section area	3200mm ²	3500mm ²	4000mm ²	6000mm ²
11	Max. width of rim band	350mm	410mm	500mm	800mm
12	Max. thickness of rim band	4.5mm	8mm	10mm	13mm
13	Min. diameter of rim welded	250mm	400mm	400mm	500mm
14	Cooling water flow rate	4000 Liters/Hour	4500L/H	5000L/H	6000L/H
15	Pressure of cooling water	0.2~0.4MPa	0.2~0.4MPa	0.2~0.4MPa	0.2~0.4MPa
16	Temperature of cooling water	No more than 20 °C	No more than 20 °C	No more than 20 °C	No more than 20 °C
17	Rejection rate	No more than 0.5%	No more than 0.5%	No more than 0.5%	No more than 0.5%



TRIMMER - PLANISHER - END CUTTING UNIT - production process

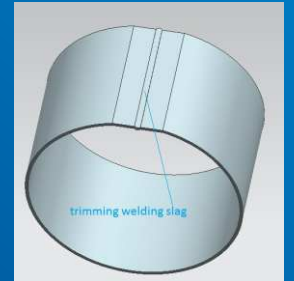

Trimming Welding Slag

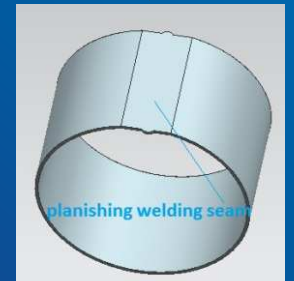

Planishing Welding Seam

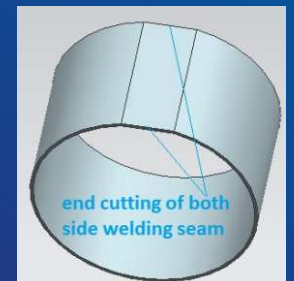

End Cutting Welding Slag



TRIMMER - PLANISHER - END CUTTING UNIT - specification



No.	Description		Data Of Trimmer-Planisher-End Cutting Unit		
1	Main machine spec	trimmer	BZJ-500B	BZJ-600B	BZJ-800B
		planisher	GYJ-500G	GYJ-600G	GYJ-800G
		end cutting machine	DQJ-500G	DQJ-600G	DQJ-800G
2	Power supply		AC 380V/3phase/50Hz	AC 380V/3phase/50Hz	AC 380V/3phase/50Hz
3	Rated input power		37KVA	45KVA	55KVA
4	Maximum clamping force for trimming		6Tons	9Tons	12Tons
5	Maximum trimming force		6Tons	9Tons	12Tons
6	Maximum clamping force for planishing		6Tons	9Tons	12Tons
7	Maximum planishing force		6Tons	9Tons	12Tons
8	Maximum cutting force		28Tons	40Tons	53Tons
9	Diameter of cutting oil cylinder		125mm	200mm	220mm
10	Pressure of hydraulic system		12Mpa	12MPa	14Mpa
11	Maximum thickness of rim band		5mm	8mm	13mm
12	Width range of rim band		220mm~350mm	300mm~500mm	450mm~800mm
13	Diameter range of rim band		280mm~450mm	400mm~650mm	600mm~1000mm



HORIZONTAL FLARING MACHINE - production process

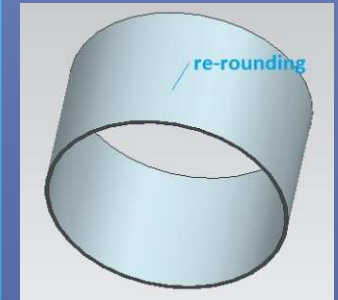

After Re-Rounding



Initial Flaring
By
Flaring Die

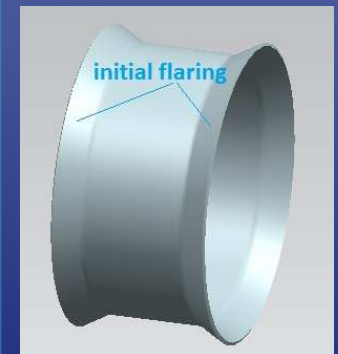



HORIZONTAL FLARING MACHINE - specification

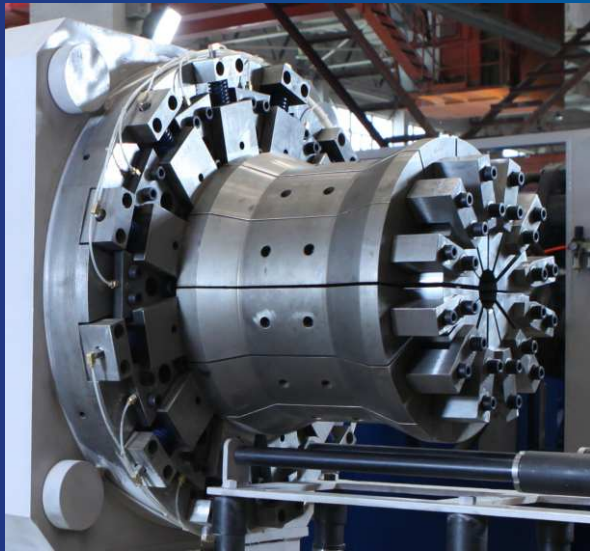

Adopting 12 Pyramids Flaring Die

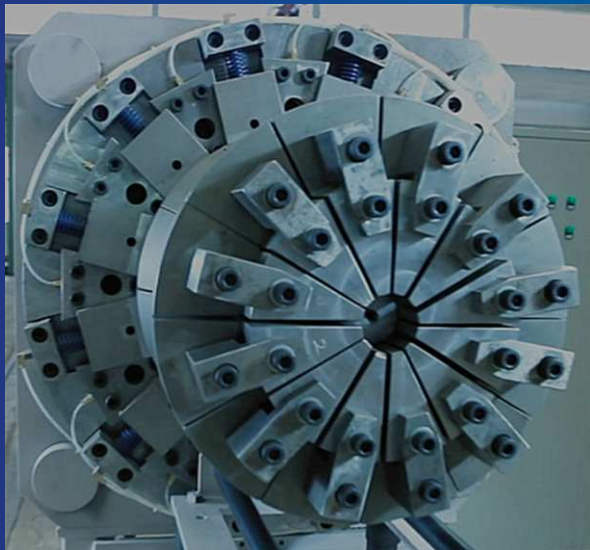

Specification of Horizontal Flaring Machine

Model Number	KKJ-315	KKJ-500
Diameter of flaring oil cylinder	320mm	400mm
Spreading force	100Tons	220Tons
Rated Operation Pressure	16MPa	22MPa
Takt Time	15S	18S
Noise and vibration	< 85 dB	< 85 dB

Optional automatic loading/unloading device

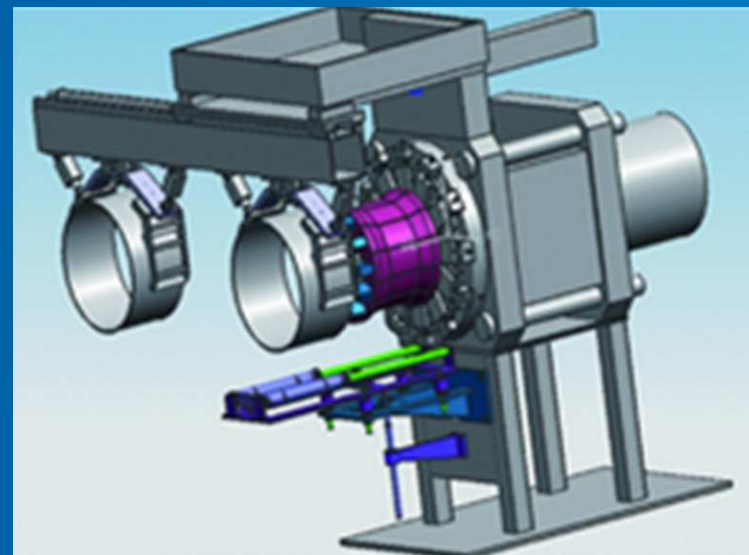



ROLL FORMING MACHINE - production process

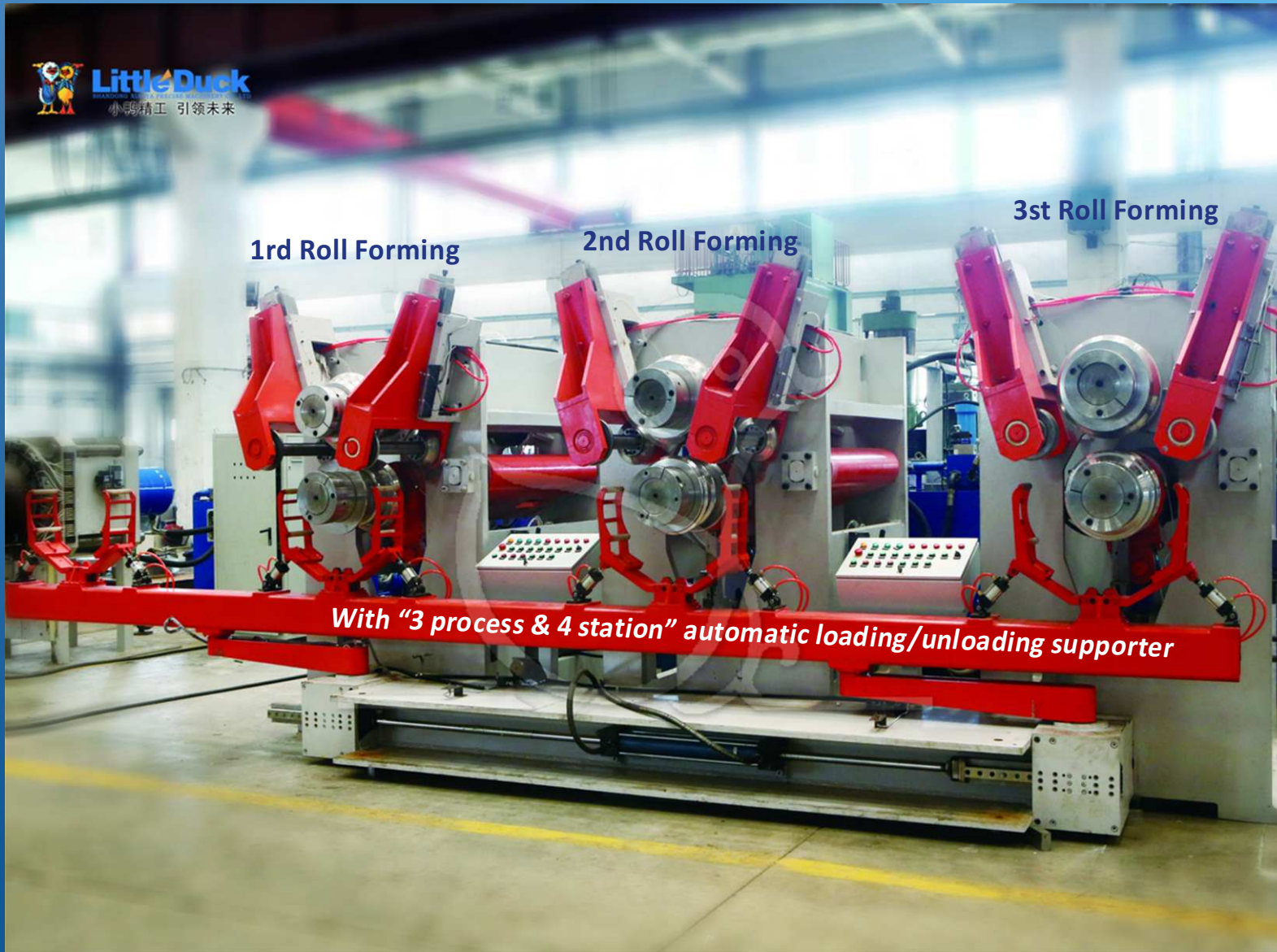

1st Roll Forming

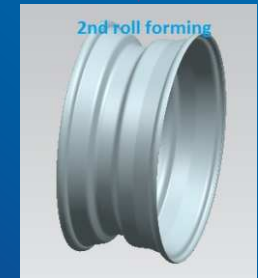

2nd Roll Forming



3rd Roll Forming



ROLL FORMING MACHINE - specification



No.	Description	Data of Roll Forming Machine		
		GX-23/300	GX-45/600	GX-48/800
1	model number	GX-23/300	GX-45/600	GX-48/800
2	rolling force	230KN	400KN	500KN
3	motor power of hydraulic station	62.5Kw	82.5Kw	165KW
4	spindle length for setting die	350mm	670mm	900mm
5	upper and lower shaft speed	220r/min	200r/min	200r/min
6	spindle material and size	40Cr/140mm	40Cr/200mm	40Cr/220mm
7	distance between upper and lower shaft	240~380mm	340~480	380~520
8	travel of lower shaft	140mm	140mm	140mm
9	feeding speed adjustable range of lower shaft	2~10mm/s	2~10mm/s	2~10mm/s
10	angle adjustable range of lower shaft	-0.35°~0.17°	±0.35°	±0.35°
11	travel of side guide roller	100mm	140mm	160mm
12	travel adjustable range of side guide roller	50mm	50mm	50mm
13	maximum diameter of guide roller	200mm	220mm	240mm
14	rated input voltage	380V	380V	380V
15	rated input power capacity	62.5Kw	82.5Kw	165Kw
16	copper cable suction, at single core 3+2 wire	70mm ²	90mm ²	180mm ²
17	cooling water rate of hydraulic station	2000L/H	3000L/H	4000L/H





HORIZONTAL EXPANDING MACHINE - production process

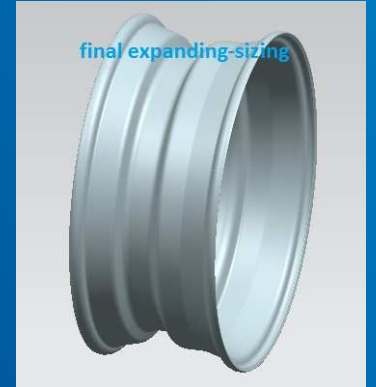
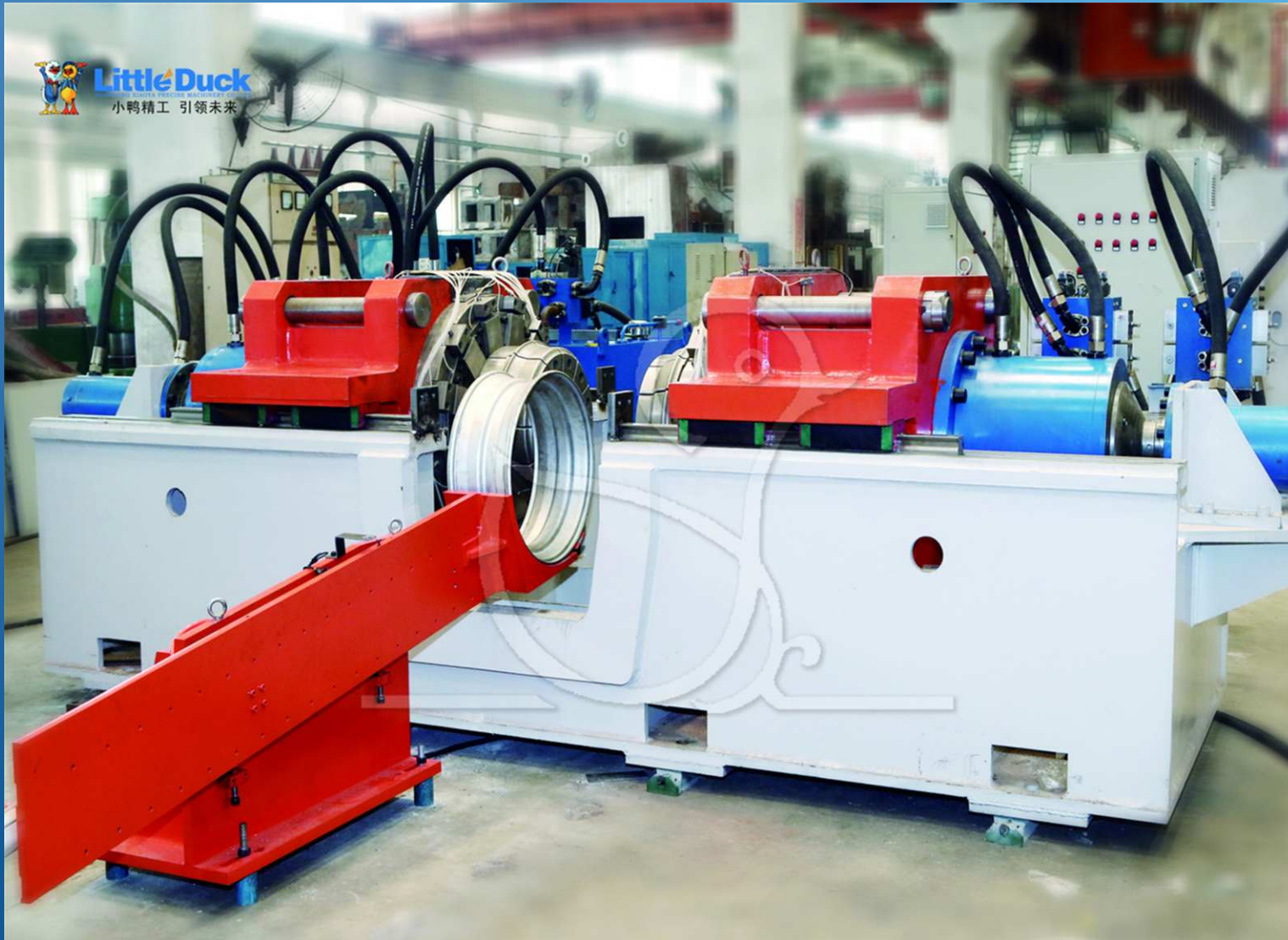

Final Expanding - Sizing





HORIZONTAL EXPANDING MACHINE - specification



No.	Description	Data of Horizontal Expanding Machine		
		KZJ-200X2	KZJ-315X2	KZJ-500X2
1	model number	KZJ-200X2	KZJ-315X2	KZJ-500X2
2	rim maximum width	200mm	300mm	500mm
3	rim maximum thickness	4mm	5mm	9mm
4	rim diameter range	200~400mm	300~470mm	450~600mm
5	fast feed cylinder thrust	70KN	110KN	150KN
6	expanding force of hydraulic cylinder	1600KN	2000KN	2500KN
7	Rated hydraulic pressure	20MPa	20MPa	20MPa
8	installed power	22KW	33KW	33KW
9	tatk time	15S	18S	23S
10	rim calibration diameter tolerance on both ends	0.3mm	0.5mm	0.5mm
11	translation accuracy of machine tool slide block	0.015mm	0.015mm	0.015mm
12	displacement sensor precision	0.01mm	0.01mm	0.01mm
13	Noise and vibration	< 85 dB	< 85 dB	< 85 dB





VALVE HOLE PUNCHING PRESS - production process & specification

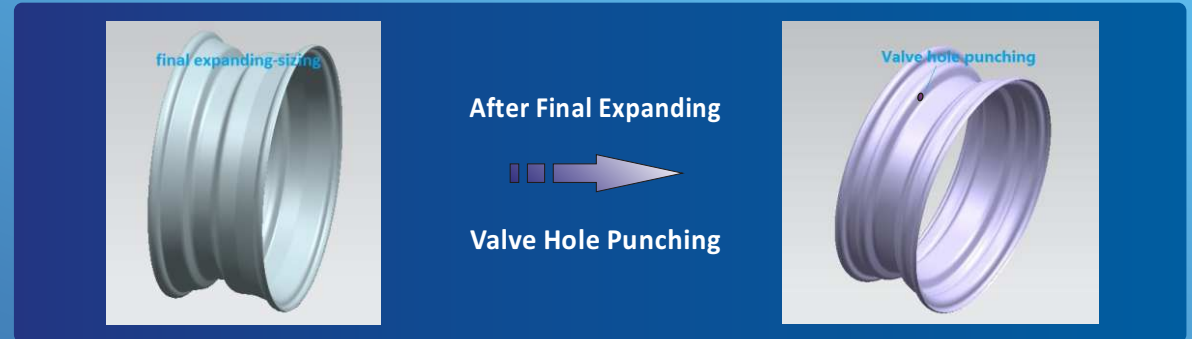

No.	Description	Data of Valve Hole Punching Press	
1	model number	YCK-400	YCK-800
2	nominal press force of main slider	400KN	800KN
3	maximum travel of slider	300mm	400mm
4	nominal press force of punching hole	250KN	320KN
5	maximum travel of punching cylinder	25mm	25mm
6	max. distance between slider and working table	670mm	670mm
7	slider size	200×200mm	300×200mm
8	throat depth	180mm	200mm
9	working table size	380×180mm	380×180mm
10	vertical height from working table to floor	750mm	750mm
11	production efficiency	> 6pcs/min	> 4pcs/min
12	motor power	11.5Kw	18.5Kw



LOCATION & CONTACT



中國的行政區分布

Distribution of Administrative Divisions in China



LOCATION

Jinan City, Shandong Province, CHINA

AIRPORT

Jinan International Airport

SEA PORT

Qingdao Port, China

MANUFACTURER

Shandong Xiaoya Precise Machinery Co., Ltd.

EXPORTER

Shandong Xiaoya Group Imp. & Exp. Co., Ltd

No.51 Gongye Nan Road, Jinan 250101 China

<http://www.littleduckgroup.com.cn>

Tel: 0086-531-8312 2094, 8312 2068,

8312 2326, 8312 2599

Fax: 0086-531-8312 2009

Email: jn_yongxin@126.com